

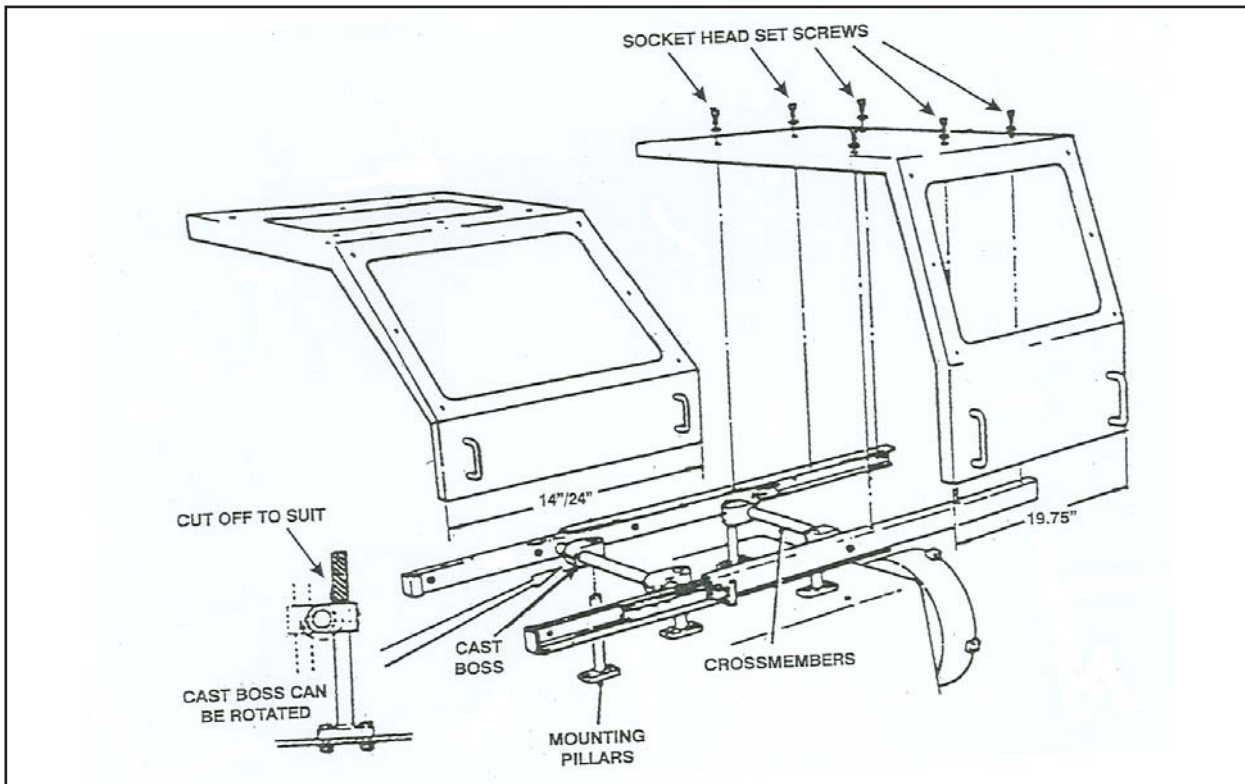

FLEXBAR MACHINE CORPORATION
250 GIBBS ROAD • ISLANDIA, NY 11749
631-582-8440 • FAX 631-582-8487
www.flexbar.com • email: sales@flexbar.com

Installation Instructions for Sliding Lathe Shields

Model Numbers 13079, 13080, 13081, 13082, 13083 and 13084



1. Remove all packing material from the shield and its mounting assembly.
2. Measure how high the underside of the shield is to be above the headstock of the lathe in order to clear the chuck. Then cut the mounting pillars to length if necessary.
3. The four pillars can then be bolted to the headstock using M8 bolts, making sure that the assembly is located so as to allow the shield to slide back far enough to expose the chuck.
4. The pillar can be fixed anywhere along the length of the crossmembers, and either to the right or left of them by sliding or rotating the cast boss into which it locates. The cast boss clamps to the crossmember and pillar with grub screws.
5. This flexibility of mounting position ensures that the pillar can be fixed without interfering with any part of the machinery housed within the headstock.
6. With the chassis located to the pillars, fix the shield (any model) to the chassis using six socket set screws provided, and check that access to the machine is not impeded.